

Spectra Connect Ceiling Track Systems

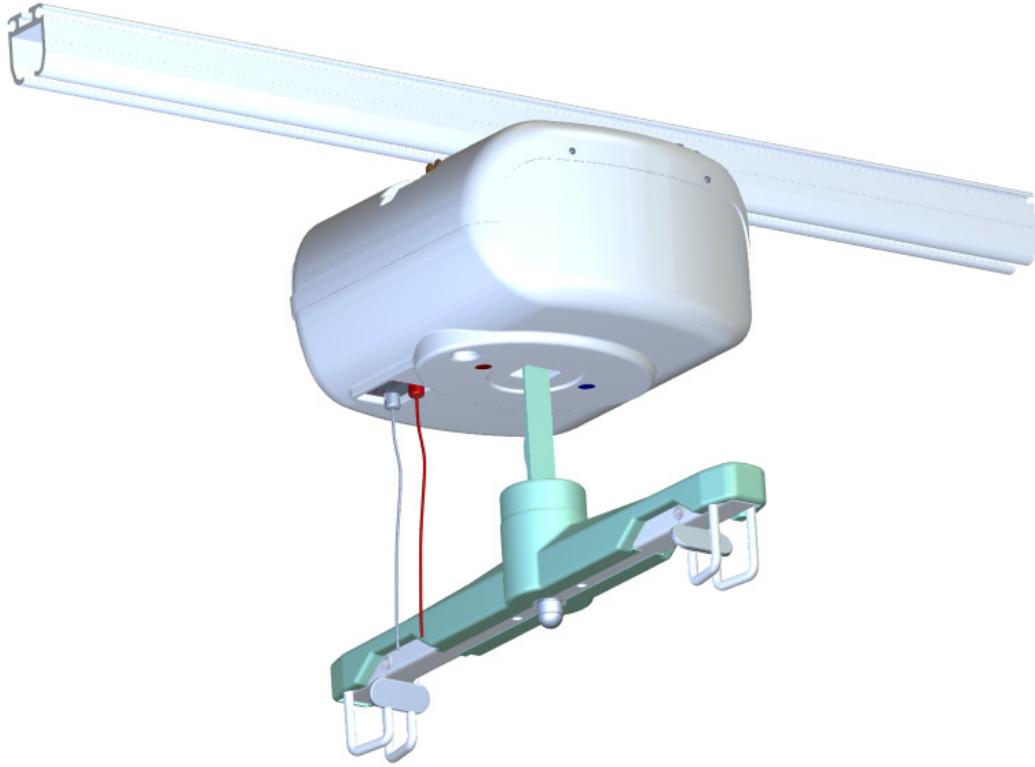

Operator Manual

OPERATOR MANUAL

SPECTRA CARE products are patented or patent pending. Patent information is available by contacting SPECTRA CARE

It is the policy of SPECTRA CARE to continuously develop all products and therefore reserve the right to make technical alterations and/or updates without notice.

The content of this publication may not be copied either whole or in part without the consent of SPECTRA CARE.

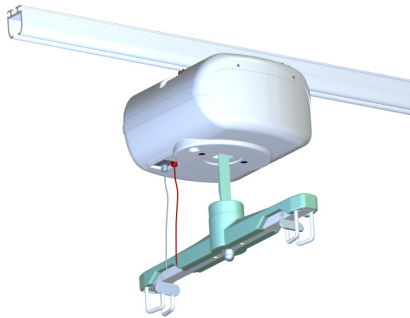

Table of Contents

<u>About the Products</u>	1
HS200 Hoist	2
<u>Preparation before use</u>	2.1
<u>Safety Precautions</u>	2.2
<u>Operation</u>	2.3
<u>Technical Data</u>	2.4
<u>Maintenance</u>	2.5
XY Link	3
<u>Preparation before use</u>	3.1
<u>Safety Precautions</u>	3.2
<u>Operation</u>	3.3
<u>Technical Data</u>	3.4
<u>Maintenance</u>	3.5
<u>Trouble Shooting</u>	4

About the Products

Before attempting to use any product, the operator must read the relevant sections relating to their specific installation.



HS200 HOIST

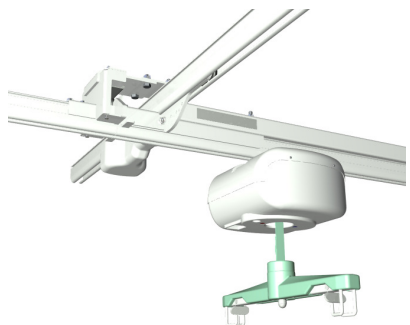

XY LINK

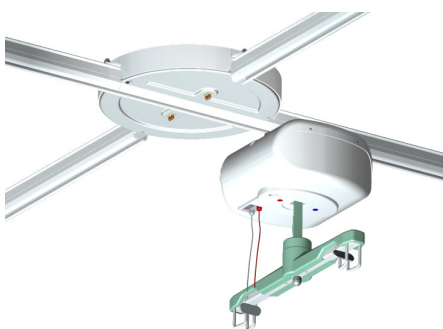

TURNTABLE



GANTRY

The Spectra HS200 is a fixed ceiling track hoist intended for lifting and transferring persons. The unit is mounted on a rail system which has been adjusted to fit the purpose of the designed area. The rail system is mounted rigidly as a single rail system or as an XY System (H-Frame). The rail system is adjusted to satisfy the needs and possibilities in each room. A closer description of the components of the rail system can be found in the Moving and Handling Brochure.

The XY Link is a device that allows the hoist to travel from one room to another room via the link device. It is used on systems: XY to XY and XY to single rail.







The Turntable allows the hoist to go off in up to four directions from 15 – 90 degrees. They are powered and easily controlled via the hoist handset.

Quick fit adjustable height and adjustable width gantry able to span up to a standard double bed and wheelchair.

Preparation Before Use

Upon completion of the installation only by an authorised service representative/dealer, the engineer should have checked to make sure that all the equipment is safely installed and in good working order.

However it is the operator's responsibility to ensure that:

-  They have been fully trained in the use of this equipment.
-  The hoist is not used for lifting over its stated capacity, (HS200 -200kg).
-  The hoist is fully charged before use.
-  Periodic visual checks are carried out for lifting tape wear; bent or loose bracketry; cracked casings; loose fixings. As well as to listen for any unusual noises when the hoist is in motion.
-  There are no obstacles along the track route that the client can injure themselves on.
-  The sling loops are securely on the spreader bar hooks and behind the sprung loaded clip.
-  The correct sling has been identified for the user; and training has taken place for its correct use.

NOTE: It is the responsibility of the duty holder to ensure that servicing of the equipment and LOLER testing is carried out by trained engineers on an annual basis; and in accordance with the appropriate regulations.

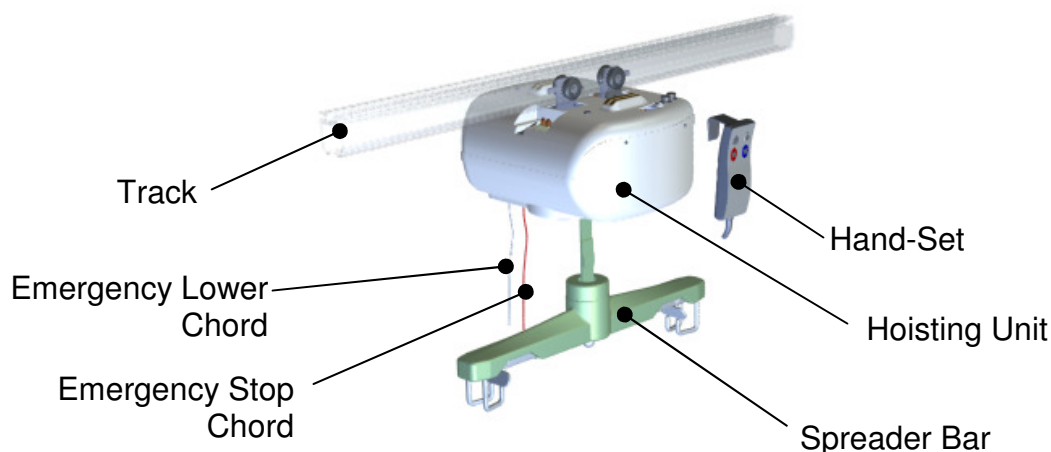

Safety Precautions

General

Before every use, the operator must ensure that the hoist and any accessories are in good working order and are safe to use. All specific instructions and information in this manual regarding safety and general precautions must be read, understood and adhered to. Any disregard to the precautions stated herein may result in personal injury and/or damage to the equipment.

On no account continue to use the hoist if any faults or irregularities are found that may influence the safety of the operator and/or client.

If Faults Occur

In the event that one of the following faults occurs do not use the hoist until it has been inspected by an authorised engineer:



Damage to the electrical cables.



Damage or failure to any safety devices.

If the client is being transferred when damage occurs;

- If the hoist is still functioning, lower the client into a safe location, and then switch off the hoist by means of the red emergency stop pull chord.
- If the hoist does not function via the handset, use the white emergency lowering chord to safely lower the client onto a chair, bed or wheel chair.

Injury to persons and/or equipment may occur if the hoist is used in an incorrect manner and if:

- Covers are removed by unauthorised personal
- Used incorrectly
- Insufficiently maintained
- Maximum loads are exceeded
- Unauthorised repair of equipment
- Track system is modified by an unauthorised person.

Lifting and Transferring

When lifting and transferring a client using the hoist system it is useful for the operator to remember the following points:

- When lifting, try to locate the hoist directly over the centre of the client as this will stop the client sliding forwards or backwards.
- Take up the slack slowly ensuring the client is comfortable and not being pinched or forced in any way.
- Do not lift the client too high, they will feel less anxious if they are under shoulder height.
- If the operator is not the client, stand to the side of the hoist; turn the client to face the direction of travel.
- Whilst traversing, keep a look out for obstructions across your path.

When reporting an incident, in the first instance call the duty holder.

Operation

Battery Charging

The HS200 has two methods of charging the battery depending on the type of installation.

1. In-Line charging – the hoist does not need any input from the operator and will automatically charge when needed.
2. Charge cam – the hoist must be placed at the end of the track where the cam is located in order to charge the batteries.

In both instances the hoist will indicate that it is on charge by flashing a line across the display.

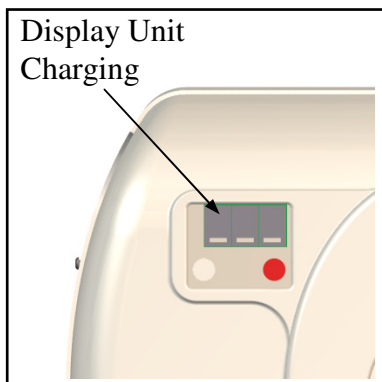

When the battery voltage falls below a certain level, the hoist will indicate the word 'bAt' across the display.

At this time the hoist may still be used for performing approximately 3-6 lift cycles. However, fully discharging the batteries may lead to permanent damage.

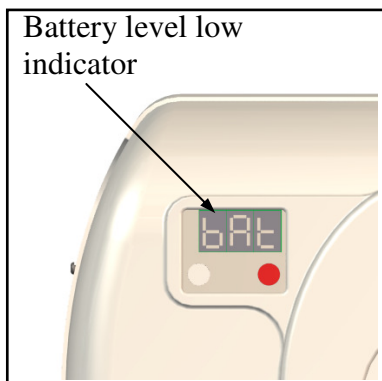

The HS200 can be supplied with powered traverse, or manual traverse (left and right movement). In both cases the hoist will come with a four button handset.

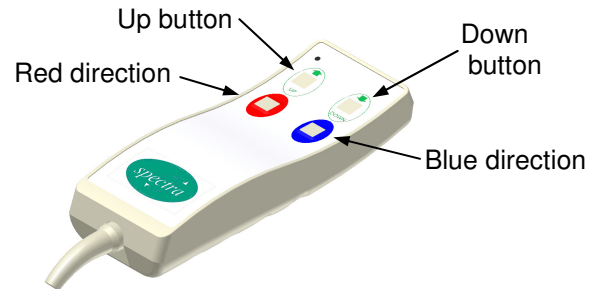

In addition, if the hoist is used with a turntable it will come with a six button handset. With an XY system, it will come with a six or four button handset depending on whether power or manual traverse has been chosen. (See pages 3.3 and 4.3).

Emergency Stop and Lower

The HS200 is supplied with emergency stop and emergency lower functions as standard.

In the event the hoisting system develops a fault, the red emergency stop chord should be pulled and help sort via the duty holder. If the main batteries fail, the hoist will be able to lower by means of the back up system. This is the white emergency lower chord. This will allow the hoist to lower only, although the non-friction wheels will allow you to push the hoist along the track if necessary for a short distance. (not recommended for long periods as may apply flat areas to the wheels which will then not rotate properly).

Technical Data

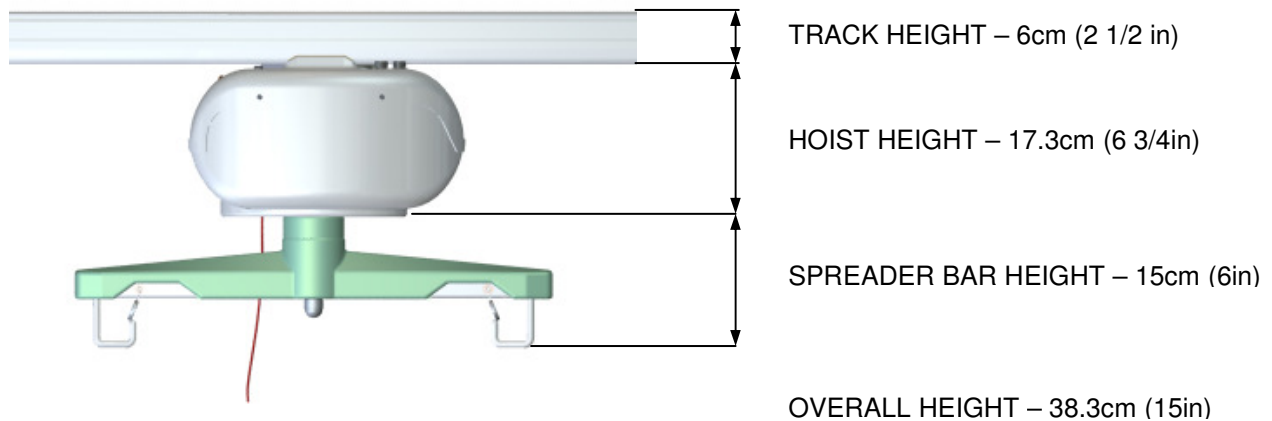

Hoist Weight:
12.5kg

Spreader Bar Weight:
2.2kg

Lifting Capacity (SWL):
200kg (31.6st)

Materials:

Chassis;	Steel
Covers;	ABS
Track;	Aluminium

Motor:
24vdc

Batteries:

Main;	Qty 2, Rechargeable, 12vdc, 5Ah
Emergency;	Qty 1, 12vdc, 1.2Ah

Lifting Height:
2.1m

Maintenance

General

If, after charging the hoist performs slowly and/or quickly runs out of charge; it may be that the batteries are in need of replacement. In this instance contact the duty holder to report the problem.

The hoist will need to be serviced annually or after 1000 lifts (whichever is sooner). Once 1000 lifts has been reached, a 'spanner' symbol will appear in the display, and an audible sound will be heard after every button operation. At this time an appointment should be made, via the duty holder, for an engineer to call and service the hoist. The counter will reach 9999 then start again.

NOTE: This is an indicator of Service due; it does not stop the operation of the hoist.

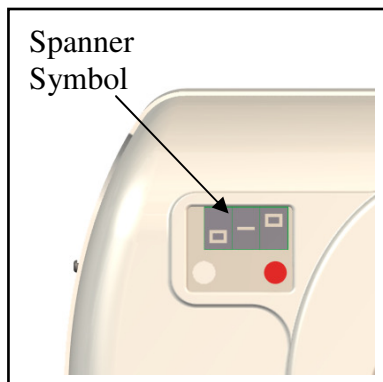

 The hoist should only be serviced by a trained, authorised person.

 The hoist should only be used provided it has been fully maintained and LOLER tested.

Cleaning the Hoist

The hoist cover is made from a molded plastic. If possible, try to keep the hoist out of UV light as much as you can, This will help to keep the finish from discolouring. To clean the hoist cover and ancilliary components including lifting tape; spreader bar; handset.

Remove any dirt, dust etc, use warm soapy water only and wring the cloth out well. After cleaning, remove any remaining residue with a dry cloth. Buff covers using a lint free cloth.

 DO NOT ALLOW EXCESS WATER TO ENTER THE HOIST OR THE HANDSET.

 DO NOT USE ANY ABRASIVE CLEANERS.

 DO NOT USE ANY CHEMICAL CLEANERS.

Preparation Before Use

The XY Link device allows the hoist to travel between track systems from one room to another without the need to transfer to wheel chair or via means of lanyard strap. The mechanism is checked and tested after installation to ensure it works properly and safely.

The XY Link can be at one end of the link track or both, depending on the installed system/s.

The boom section of the XY system should only be moved when the hoist is suspended from it.



On no account should the boom section be moved when the hoist is no longer suspended from it and the hoist has moved from it via the link to an adjacent track system.



Never move the hoist along the track from the boom or track unless they are properly in line and the boom has stopped moving.

Safety Precautions

Tracks must be aligned and locked in place before the hoist is driven through the link mechanism, failure to do so could result in serious injury.

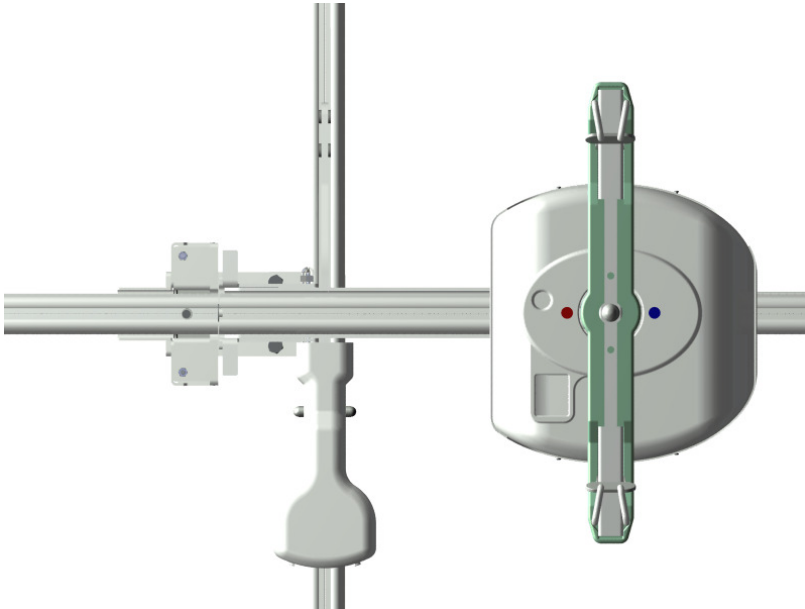

TRACK ALIGNED – SAFE TO DRIVE HOIST THROUGH

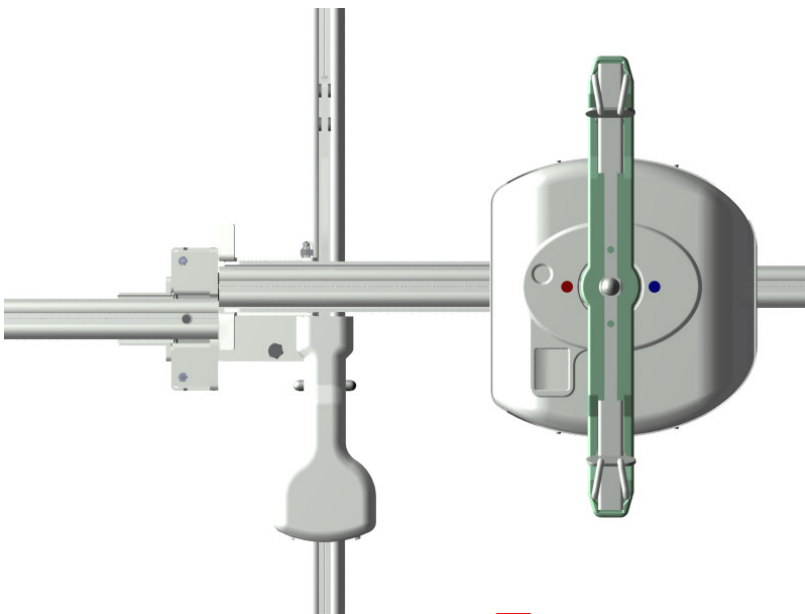

TRACK MISS-ALIGNED –



NOT SAFE TO DRIVE HOIST THROUGH.

Operation

General

The operation of the XY Link requires no input from the operator other than due care and vigilance.

When moving the boom section of the XY system into alignment with the link, ensure correct alignment as this raises the safety gates on both sections of the link allowing the hoist to pass through. Correct alignment is obtained by positioning the boom section in line with the link unit; the mechanism will automatically centre the two systems exactly thereafter.

If the boom section is miss-aligned the safety gates will not allow the hoist to pass through, causing the hoist to suddenly jolt to a stop and so distressing the user.

Once the hoist has passed through the link unit, the boom section must **not** be moved out of alignment for any reason.



Before moving the hoist back onto the XY system from the adjoining track system, check to ensure the boom section has not been accidentally moved out of alignment and is correctly aligned with the link unit.

Failure to carry out this could result in serious injury.

The XY system can be supplied as either a manual traverse system or a powered traverse system.

The manual traverse system will be supplied with the standard four button handset.

(See HS200 Hoist - **Operation** p2.3).

The powered traverse system will be supplied with a six button handset, the additional two buttons for the powered boom traverse.

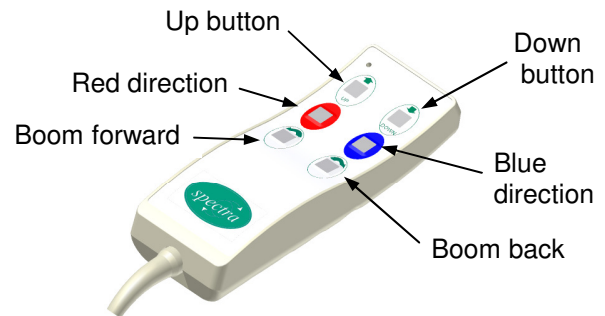

XY LINK

Technical Data

Mechanical link with safety device.

Spring loaded clapper box on moving boom.

Spring loaded safety pin on fixed track.

2 sealed roller bearings with moulded wheels fixed to clapper box for actuation of gate operation.

Maintenance

The Link unit should be regularly checked by the operator for any faults/irregularities. These would include but are not limited to:

- Bent pins on both fixed and/or boom end link unit mechanisms.
- Stiff movement on rising parts of both fixed and moving units.
- Mechanisms not returning to locked position when boom is moved out of alignment with fixed track.



If any faults/irregularities are found, including those listed above; contact the duty holder immediately.

Trouble Shooting

If you are not able to solve the fault yourself using the suggestions below, then contact the duty holder to see if it can be resolved over the phone. If it is not possible to remedy the fault over the phone, an appointment will be made for an engineer to visit.

Product	Symptom	Possible Cause	Action
HS200	Nothing happens when I press a button	Red emergency chord may have been pulled.	Pull chord once and retry functions.
		Batteries may be discharged.	If using charge cam; Pull hoist to cam, check for charging indicators on display. If using in-line charging; Check power unit for green led light. If no light is visible check power has not been switched off at source.
		Faulty handset	If infra-red handset; Batteries in handset may need replacing. If cabled handset; Contact duty holder to arrange an appointment for an engineer to call out.
	Spreader bar moves up when I press the down button and vica-verca.	Problem with the limit switch.	Contact duty holder to arrange an appointment for engineer to call out.
	Intermittent Audible beep from handset.	Batteries getting low.	See section above. (Batteries may be discharged).
XY Link	Boom section is not self-aligning after positioning.	Wheels are damaged.	Contact duty holder to arrange an appointment for engineer to call out. (DO NOT USE).
		Gate is sticking up.	