

# Spectra Connect Ceiling Track Systems

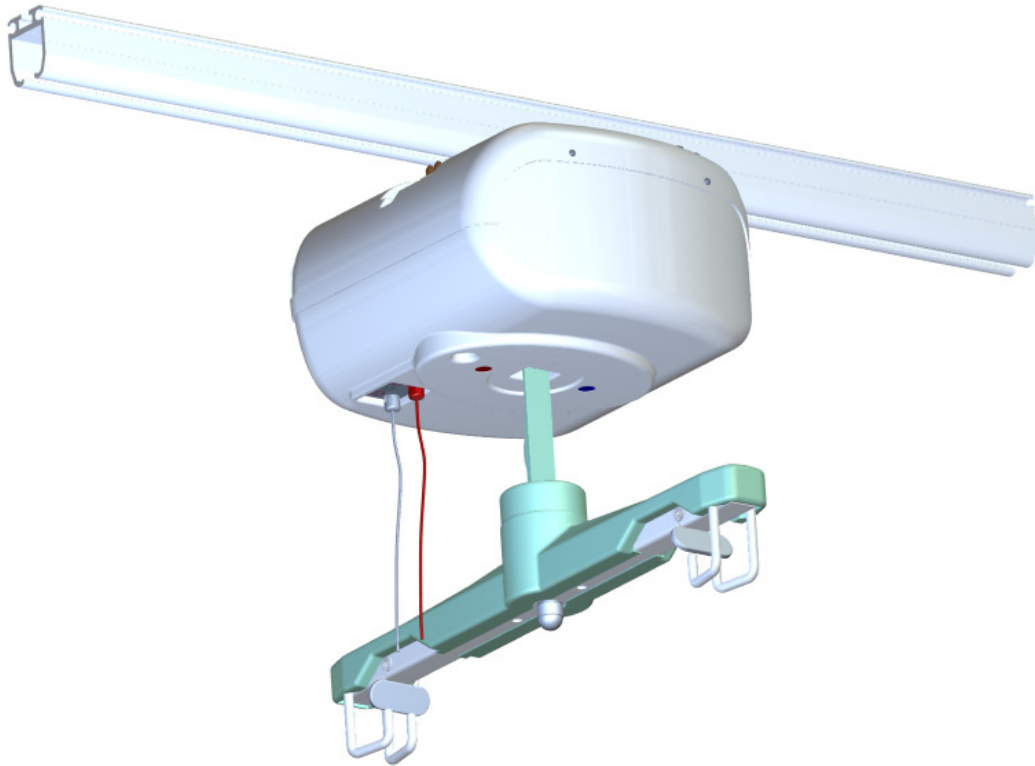

# Operator Manual

SERIAL NUMBER:

*OPERATOR MANUAL*

SPECTRA CARE products are patented or patent pending. Patent information is available by contacting SPECTRA CARE

It is the policy of SPECTRA CARE to continuously develop all products and therefore reserve the right to make technical alterations and/or updates without notice.

The content of this publication may not be copied either whole or in part without the written consent of SPECTRA CARE.



---

## Table of Contents

---

<b>Section</b>	<b>Content</b>	<b>Page</b>
1.....	<a href="#"><u>About the Products</u></a> .....	1
2.....	<b>HS200 Hoist</b>	
2.1.....	<a href="#"><u>Preparation before use</u></a> .....	2
2.2.....	<a href="#"><u>Safety Precautions</u></a> .....	3
2.3.....	<a href="#"><u>Operation</u></a> .....	4
2.4.....	<a href="#"><u>Technical Data</u></a> .....	5
2.5.....	<a href="#"><u>Maintenance</u></a> .....	6
3.....	<b>XY Link</b>	
3.1.....	<a href="#"><u>Preparation before use</u></a> .....	7
3.2.....	<a href="#"><u>Safety Precautions</u></a> .....	8
3.3.....	<a href="#"><u>Operation</u></a> .....	9
3.4.....	<a href="#"><u>Technical Data</u></a> .....	10
3.5.....	<a href="#"><u>Maintenance</u></a> .....	10
4.....	<b>Turntable</b>	
4.1.....	<a href="#"><u>Preparation before use</u></a> .....	11
4.2.....	<a href="#"><u>Safety Precautions</u></a> .....	11
4.3.....	<a href="#"><u>Operation</u></a> .....	12
4.4.....	<a href="#"><u>Technical Data</u></a> .....	12
4.5.....	<a href="#"><u>Maintenance</u></a> .....	12
5.....	<b>Gantry</b>	
5.1.....	<a href="#"><u>Preparation before use</u></a> .....	13
5.2.....	<a href="#"><u>Safety Precautions</u></a> .....	13
5.3.....	<a href="#"><u>Operation</u></a> .....	13
5.4.....	<a href="#"><u>Technical Data</u></a> .....	14
5.5.....	<a href="#"><u>Maintenance</u></a> .....	15
6.....	<a href="#"><u>Trouble Shooting</u></a> .....	16
7.....	<a href="#"><u>Warranty</u></a> .....	17
8.....	<b>Company Details</b> .....	18

## ***About the Products***

Before attempting to use any product, the operator must read the relevant sections relating to their specific installation.

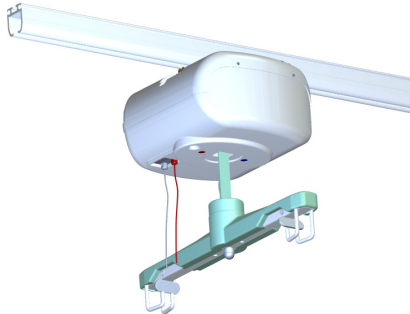

**HS200 HOIST**

The Spectra HS200 is a fixed ceiling track hoist intended for the lifting and transferring of persons. The unit is mounted on a rail system which has been adjusted to fit the purpose of the designed area. The rail system is mounted rigidly as a single rail system or as an XY System (H-Frame).

The rail system is adjusted to satisfy the needs and possibilities in each room. A closer description of the components of the rail system can be found in the Moving and Handling Brochure.



**XY LINK**

The XY Link is a device that allows the hoist to travel from one room to another room via the link device. It is used on systems: XY to XY and XY to single rail.



**TURNTABLE**

The Turntable allows the hoist to go off in up to four directions from 15 – 90 degrees.

They are powered and easily controlled via the hoist handset.









**GANTRY**

Quick fit; adjustable height and adjustable width gantry; able to span a standard double bed and wheelchair.

## 2.1 Preparation Before Use

Upon completion of the installation only by an authorised service representative/dealer, the engineer should have checked to make sure that all the equipment is safely installed and in good working order.

However it is the operator's responsibility to ensure that:

-  They have been fully trained in the use of this equipment.
-  The hoist is not used for lifting over its stated capacity, (HS200 -200kg).
-  The hoist is fully charged before use.
-  Periodic visual checks are carried out for lifting tape wear; bent or loose bracketry; cracked casings; loose fixings. As well as to listen for any unusual noises when the hoist is in motion.
-  There are no obstacles along the track route that the client can injure themselves on.
-  The sling loops are securely on the spreader bar hooks and behind the sprung loaded clip.
-  The correct sling has been identified for the user; and training has taken place for its correct use.

**NOTE: It is the responsibility of the duty holder to ensure that servicing of the equipment and LOLER testing is carried out by trained engineers on an annual basis; and in accordance with the appropriate regulations.**

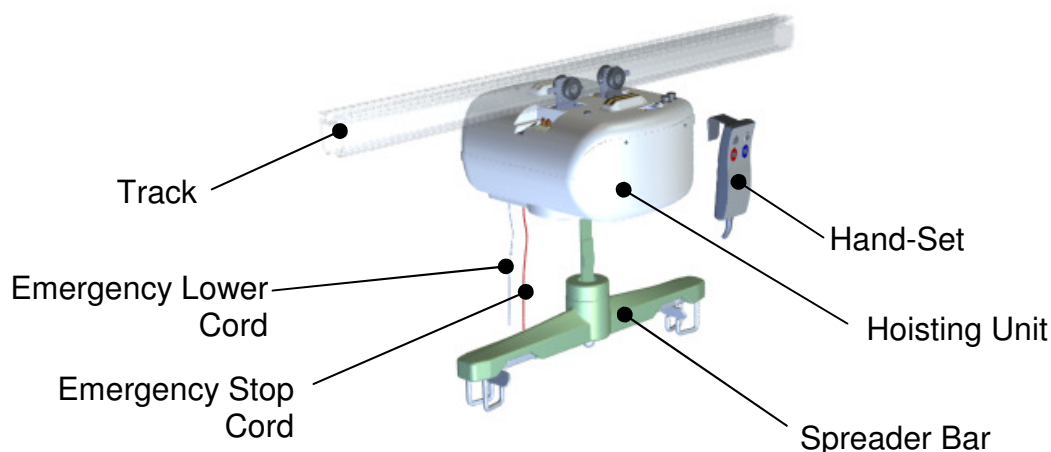

**General**

Before every use, the operator must ensure that the hoist and any accessories are in good working order and are safe to use. All specific instructions and information in this manual regarding safety and general precautions must be read, understood and adhered to. Any disregard to the precautions stated herein may result in personal injury and/or damage to the equipment.

On no account continue to use the hoist if any faults or irregularities are found that may influence the safety of the operator and/or client.

**If Faults Occur**

In the event that one of the following faults occurs do not use the hoist until it has been inspected by an authorised engineer:



Damage to the electrical cables.



Damage or failure to any safety devices.

If the client is being transferred when damage occurs;

- If the hoist is still functioning, lower the client into a safe location, and then switch off the hoist by means of the red emergency stop pull cord.
- If the hoist does not function via the handset, use the white emergency lowering cord to safely lower the client onto a chair, bed or wheel chair.

Injury to persons and/or equipment may occur if the hoist is used in an incorrect manner and if:

- Covers are removed by unauthorised personal
- Used incorrectly
- Insufficiently maintained
- Maximum loads are exceeded
- Unauthorised repair of equipment
- Track system is modified by an unauthorised person.

**Lifting and Transferring**

When lifting and transferring a client using the hoist system it is useful for the operator to remember the following points:

- When lifting, try to locate the hoist directly over the centre of the client as this will stop the client sliding forwards or backwards.
- Take up the slack slowly ensuring the client is comfortable and not being pinched or forced in any way.
- Do not lift the client too high, they will feel less anxious if they are under shoulder height.
- If the operator is not the client, stand to the side of the hoist; turn the client to face the direction of travel.
- Whilst traversing, keep a look out for obstructions across your path.

**When reporting an incident, in the first instance call the duty holder.**

### Battery Charging

The HS200 has two methods of charging the battery depending on the type of installation.

1. In-Line charging – the hoist does not need any input from the operator and will automatically charge when needed.
2. Charge cam – the hoist must be placed at the end of the track where the cam is located in order to charge the batteries.

In both instances the hoist will indicate that it is on charge by flashing a line across the display.

Display Unit Charging

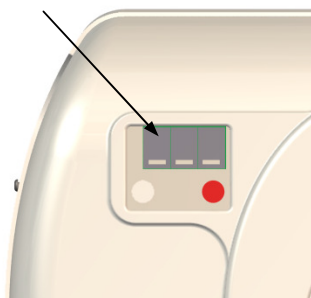

When the battery voltage falls below a certain level, the hoist will indicate the word 'bAt' across the display, and should now be recharged. The hoist may still be used for performing approximately 3-6 lift cycles. However, fully discharging the batteries may lead to permanent damage.

Battery Level Low Indicator



The HS200 can be supplied with powered traverse, or manual traverse (left and right movement). In both cases the hoist will come with a four button handset.

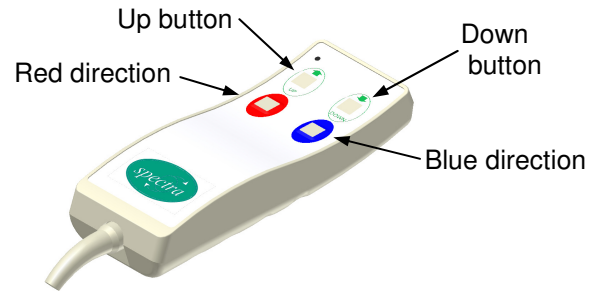

In addition, if the hoist is used with a turntable it will come with a six button handset. With an XY system, it will come with a six or four button handset depending on whether power or manual traverse has been chosen. (See sections 3.3 and 4.3).

### Emergency Stop and Lower

The HS200 is supplied with emergency stop and emergency lower functions as standard.

In the event the hoisting system develops a fault, the red emergency stop cord should be pulled and help sort via the duty holder. If the main batteries fail, the hoist will be able to lower by means of the back up system. This is the white emergency lower cord. This will allow the hoist to lower only, although the non-friction wheels will allow you to push the hoist along the track if necessary for a short distance. (not recommended for long periods as may apply flat areas to the wheels which will then not rotate properly).

**2.4 Technical Data**

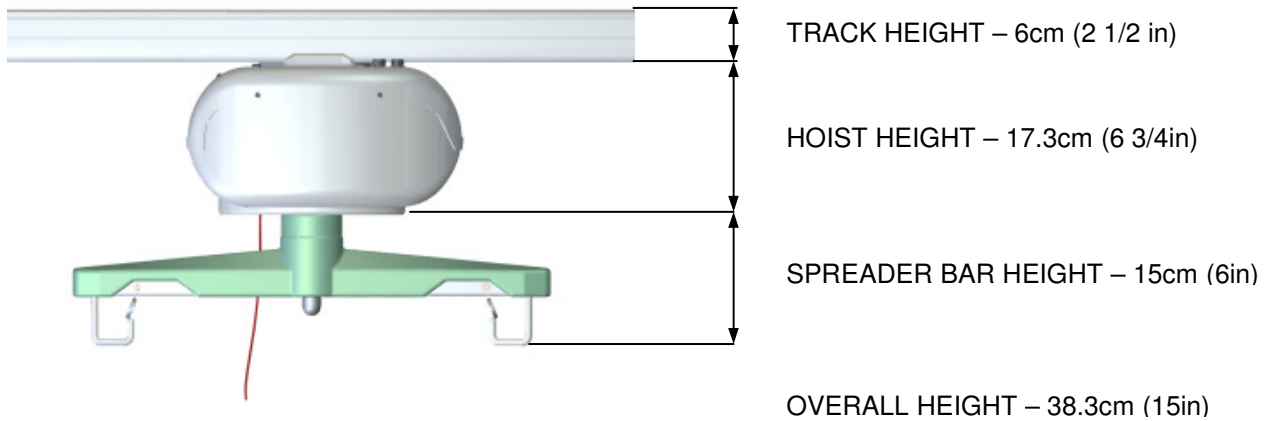

*Hoist Weight:*  
12.5kg

*Spreader Bar Weight:*  
2.2kg

*Lifting Capacity (SWL):*  
200kg (31.6st)

*Materials:*  
 Chassis; Steel  
 Covers; ABS  
 Track; Aluminium

*Motor:*  
24vdc

*Batteries:*  
 Main; Qty 2,  
 Rechargeable; 12vdc, 5Ah  
 Emergency; Qty 1, 12vdc, 1.2Ah

*Lifting Height:*  
2.1m

- Audible and visual diagnostics.
- Low battery indicator (audible and visual)
- Charging indicator
- Operations counter.
- Required service interval display.
- Integral weighing indicator device.
- Pull cord powered emergency lowering.
- Pull cord emergency stop.
- Soft start and stop in all directions.

## 2.5 Maintenance

### General

If, after charging the hoist performs slowly and/or quickly runs out of charge; it may be that the batteries are in need of replacement. In this instance contact the duty holder to report the problem.

The hoist will need to be serviced annually or after 1000 lifts (whichever is sooner). Once 1000 lifts has been reached, a 'spanner' symbol will appear in the display, and an audible sound will be heard after every button operation. At this time an appointment should be made, via the duty holder, for an engineer to call and service the hoist. He will also reset the counter so that the next 1000 lifts can be carried out.

NOTE: This is an indicator of Service due; it does not stop the operation of the hoist.

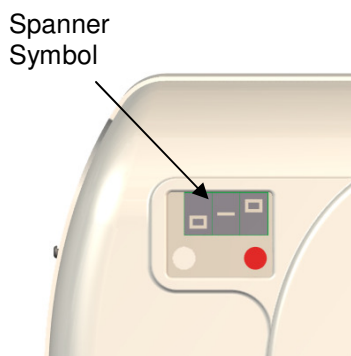

 The hoist should only be serviced by a trained, authorised person.

 The hoist should only be used provided it has been fully maintained and LOLER tested.

### Cleaning the Hoist

The hoist cover is made from a molded plastic.

If possible, try to keep the hoist out of UV light as much as you can, as this will help to keep the finish from discolouring.

To clean the hoist cover and ancillary components including lifting tape; spreader bar; handset:

Remove any dirt, dust etc, use warm soapy water only and wring the cloth out well.

After cleaning, remove any remaining residue with a dry cloth.

Buff covers using a lint free cloth.

 DO NOT ALLOW EXCESS WATER TO ENTER THE HOIST OR THE HANDSET.

 DO NOT USE ANY ABRASIVE CLEANERS.

 DO NOT USE ANY CHEMICAL CLEANERS.

---

## **3.1** ***Preparation Before Use***

---

The XY Link device allows the hoist to travel between track systems from one room to another without the need to transfer to wheel chair or via means of lanyard strap. The mechanism is checked and tested after installation to ensure it works properly and safely.

The XY Link can be at one end of the link track or both, depending on the installed system/s.

The boom section of the XY system should only be moved when the hoist is suspended from it.



On no account should the boom section be moved when the hoist is no longer suspended from it and the hoist has moved from it via the link to an adjacent track system.



Never move the hoist along the track from the boom or track unless they are properly in line and the boom has stopped moving.

## 3.2 Safety Precautions

Tracks must be aligned and locked in place before the hoist is driven through the link mechanism, failure to do so could result in serious injury.

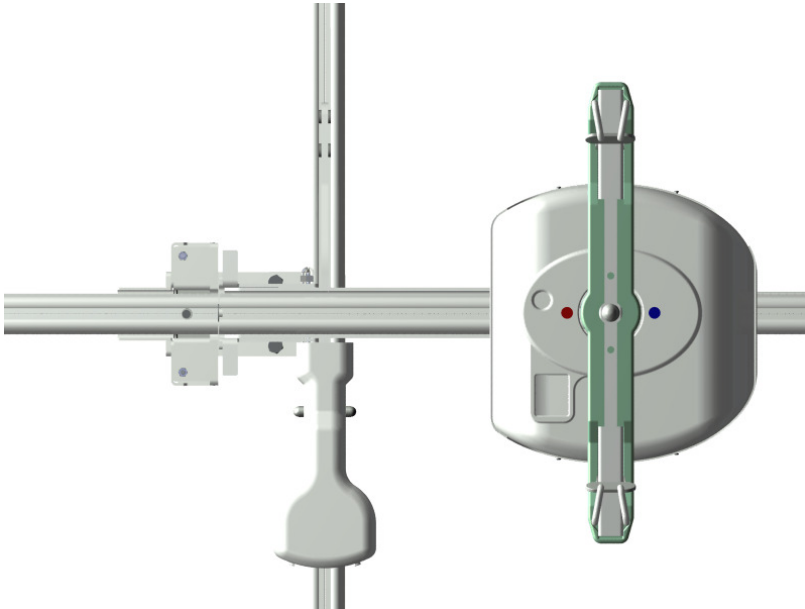

 TRACK ALIGNED – SAFE TO DRIVE HOIST THROUGH

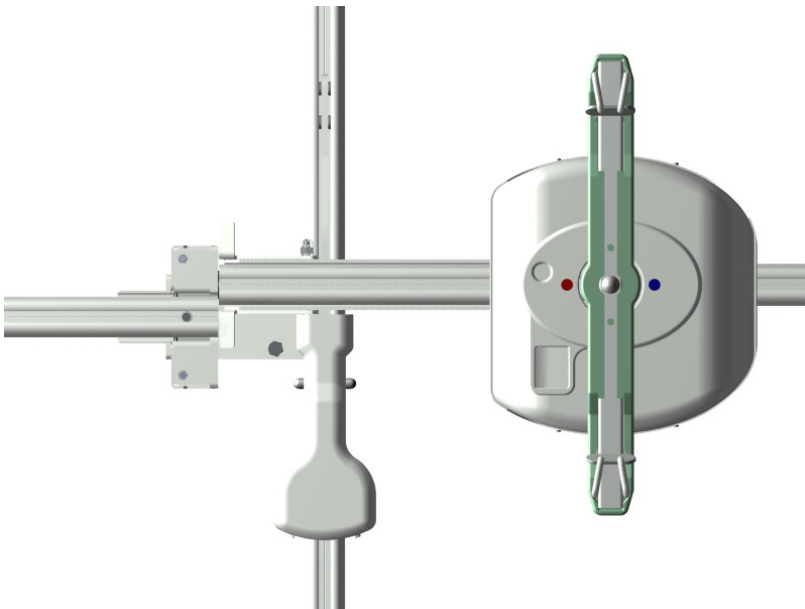

 TRACK MISS-ALIGNED –  NOT SAFE TO DRIVE HOIST THROUGH.

### 3.3

## Operation

### General

The operation of the XY Link requires no input from the operator other than due care and vigilance.

When moving the boom section of the XY system into alignment with the link, ensure correct alignment as this raises the safety gates on both sections of the link allowing the hoist to pass through. Correct alignment is obtained by positioning the boom section in line with the link unit; the mechanism will automatically centre the two systems exactly thereafter.

If the boom section is misaligned the safety gates will not allow the hoist to pass through, causing the hoist to suddenly jolt to a stop and so distressing the user.

Once the hoist has passed through the link unit, the boom section must **NOT** be moved out of alignment for any reason.



Before moving the hoist back onto the XY system from the adjoining track system, check to ensure the boom section has not been accidentally moved out of alignment and is correctly aligned with the link unit.

Failure to carry out this could result in serious injury.

The XY system can be supplied as either a manual traverse system or a powered traverse system.

The manual traverse system will be supplied with the standard four button handset.

(See HS200 Hoist - **Operation** sec. 2.3).

The powered traverse system will be supplied with a six button handset, the additional two buttons for the powered boom traverse.

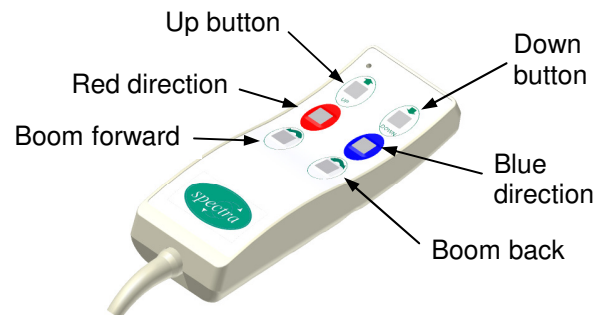

---

## **3.4** *Technical Data*

---

Mechanical link with safety device.

Spring loaded clapper box on moving boom.

Spring loaded safety pin on fixed track.

2 sealed roller bearings with moulded wheels fixed to clapper box for actuation of gate operation.

---

## **3.5** *Maintenance*

---

The Link unit should be regularly checked by the operator for any faults/irregularities.

These would include but are not limited to:

- Bent pins on both fixed and/or boom end link unit mechanisms.
- Stiff movement on rising parts of both fixed and moving units.
- Mechanisms not returning to locked position when boom is moved out of alignment with fixed track.



If any faults/irregularities are found, including those listed above; contact the duty holder immediately. You will need the hoist serial number.

## TURNTABLE

### 4.1 *Preparation Before Use*

The turntable device allows the user to access specific areas of the room or building where an XY System has not been deemed necessary.

The functionality of the turntable is very straightforward.

When the hoist is driven on to the turntable a small indicator light (LED) will shine when the hoist is at the correct location to rotate the turntable. The user can have either three or four possible directions to exit, depending on the type of turntable installed. See examples below.

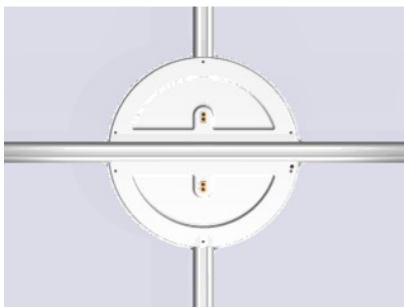

Four track exit

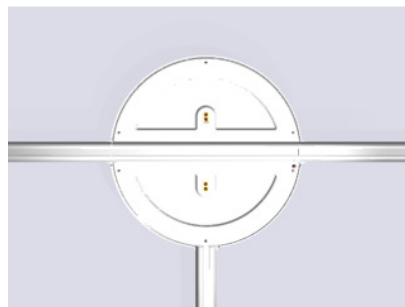

Three track exit 90deg

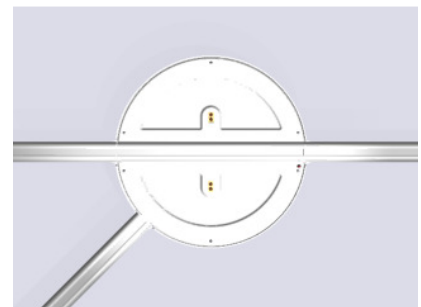

Three track exit 45deg

### 4.2 *Safety Precautions*

When driving the hoist onto the turntable, look out for the small light as this will indicate where to stop the hoist.

Ensure the turntable has fully rotated to the desired exit track before moving the hoist.

If the tracks have not correctly aligned, rotate the turntable back to the original position and listen carefully for any scraping or knocking sounds coming from the turntable. If nothing is heard try again.



In the event sounds are heard contact the duty holder and explain what is happening. You will need the hoist serial number.

## TURNTABLE

### 4.3 **Operation**

The turntable will always be aligned to the last track used to exit from it. Drive the hoist onto the turntable, stopping when the small light (LED) comes on. Using the handset, press the rotate buttons to turn the turntable in the desired direction. The turntable will continue to turn until it locks into place aligned to the desired exit track. At this point the button, if still pressed will not function. Only the opposite rotation button will function if you need to rotate back the other way again. Once locked in place you can safely drive the hoist off the turntable and onto the track. The turntable will not function when the hoist is not on it.

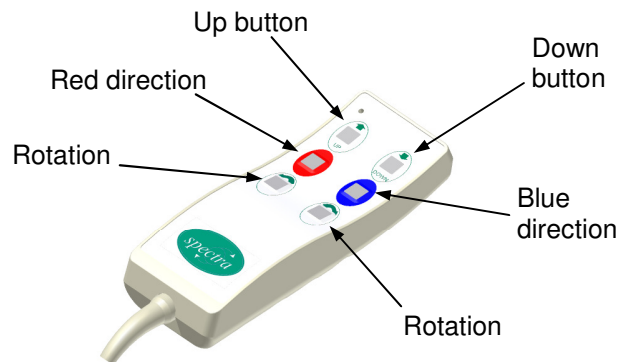

### 4.4 **Technical Data**

*Lifting Capacity (SWL):*  
220kg (34.6st)

*Materials:*

Chassis;	Steel
Covers;	ABS
Track;	Aluminium

*Motor:*

24vdc.

*Turning speed:*

90mm/sec.

Hoist position indicator light (LED)

Soft start function

Non-functioning until hoist is driven on

Can be set for angles from 15 to 180 degrees.

### 4.5 **Maintenance**

No maintenance is required by the client.

Servicing of the turntable should be carried out by a trained, authorised person only, at the annual specified service intervals.

Any problems or concerns with the turntable, call the duty holder. You will need the hoist serial number.

---

## **5.1** *Preparation Before Use*

---

The gantry should be correctly positioned and adjusted by the installation team. The gantry is supplied with the HS200 Manual Ceiling Track Hoist for which the operating recommendations are in section 2 of this operator manual. The batteries on the gantry hoist are continually charged via the power adaptor which should always be plugged into the nearest 240v domestic consumer electrical outlet which should always be switched on. Because the gantry hoist batteries are continually charged, the hoist can be left at any location along the length of the track.

- Check the stability of the gantry. The feet should have been adjusted so that it does not rock on an uneven surface. Any concerns call duty holder.
- The gantry should be in a position such that when lifting the client no forward or backward pull is encountered and only a directly vertical lift is made.
- Always position the hoist directly over the client

---

## **5.2** *Safety Precautions*

---

### **General**

Before using the gantry the operator should always ensure that the gantry is properly positioned and all accessories are in good working order, especially with regard to safety.



Once the gantry has been set up, it should not be re-positioned by the user.



Beware electrical leads may be a tripping hazard.

---

## **5.3** *Operation*

---

There is no required operation for the gantry. Once erected it is a static unit that will require no further adjustment or movement. However the gantry hoist will follow the same procedures as in section 2 of this manual.

**GANTRY**

**5.4**

**Technical Data**

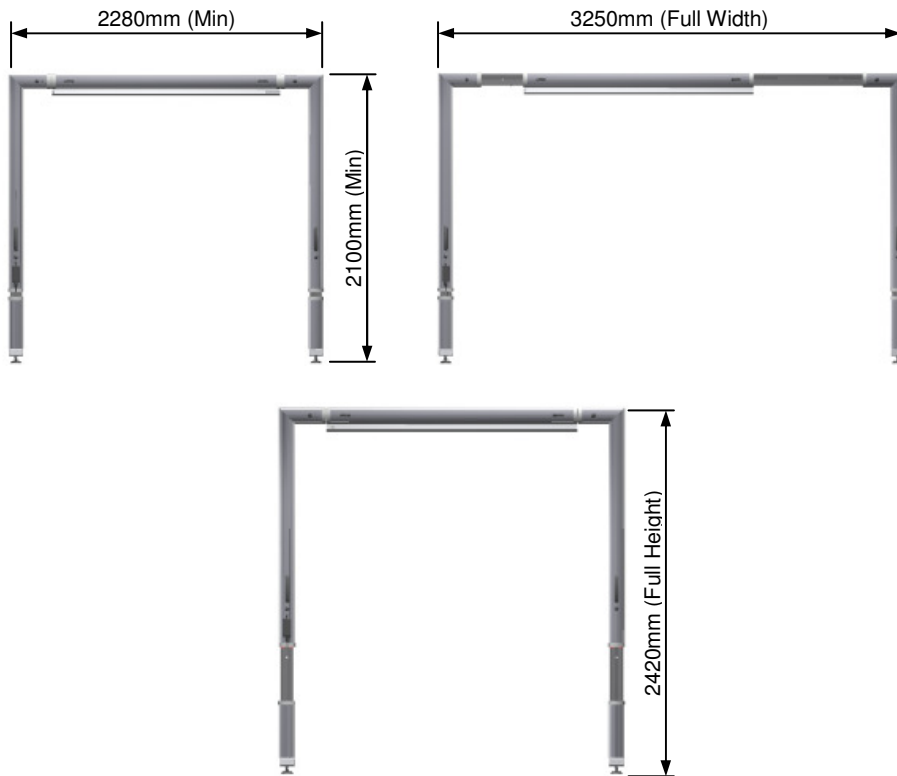

*Lifting Capacity (SWL):*  
220kg (34.6st)

*Materials:*

Chassis;	Aluminium/Steel
Covers;	ABS Plastic
Track;	Aluminium

**5.5*****Maintenance***

---

No maintenance is required by the client.

Any problems or concerns with the gantry, call the duty holder. You will need the hoist serial number handy.

***Cleaning the Gantry***

The gantry is of anodized aluminium and the cover is made from a molded plastic.

To clean the gantry, covers and ancillary components:

Remove any dirt, dust etc, use warm soapy water only and wring the cloth out well.

After cleaning, remove any remaining residue with a dry cloth.



DO NOT USE ANY ABRASIVE CLEANERS.



DO NOT USE ANY CHEMICAL CLEANERS.

## 6.0

## Trouble Shooting

If you are not able to solve the fault yourself using the suggestions below, then contact the duty holder to see if it can be resolved over the phone. If it is not possible to remedy the fault over the phone, an appointment will be made for an engineer to visit.

Product	Symptom	Possible Cause	Action
HS200	Nothing happens when I press a button	Red emergency chord may have been pulled.	Pull chord once and retry functions.
		Batteries may be discharged.	If using charge cam; Pull hoist to cam, check for charging indicators on display. If using in-line charging; Check power unit for green LED light. If no light is visible check power has not been switched off at source.
		Faulty handset	If infra-red handset; Batteries in handset may need replacing. If cabled handset; Contact duty holder to arrange an appointment for an engineer to call out.
	Spreader bar moves up when I press the down button and vica-verca.	Problem with the limit switch.	Contact duty holder to arrange an appointment for engineer to call out.
	Intermittent Audible beep from handset.	Batteries getting low.	See section above. (Batteries may be discharged).
XY Link	Boom section is not self-aligning after positioning.	Wheels are damaged.	Contact duty holder to arrange an appointment for engineer to call out. (DO NOT USE).
		Gate is sticking up.	
Turntable	Turntable will not rotate.	Hoist is not properly aligned on the turntable.	Move hoist forward or back until the red LED light displays on the turntable cover. Try rotation again.

---

## 7.0 STANDARD 2 YEAR WARRANTY POLICY

---

### **General**

Spectra products are designed and manufactured by Southern Care Systems Ltd. based in Ringwood, Hampshire in Southern England and are offered with a standard 2 year warranty

We are pleased to offer a standard warranty of 2 years from the date of purchase. It is subject to the following General Terms and Conditions:

1. Should problems be experienced with any workmanship or materials within the first 2 years of use please contact your point of purchase or Southern Care Systems Ltd within normal working hours (9am -5pm, Monday - Friday).
2. Please quote the Serial Number of the product (where applicable), which will be found on the front page of this booklet, and on the product itself.
3. The product will be repaired free of charge provided that it has been used in accordance with the guidelines and recommendations set out in the relevant section of this booklet, installed, serviced and maintained by Southern Care Systems Ltd. or one of their appointed agents.
4. The Warranty does not cover replacements, adjustments or repairs arising as a consequence of normal wear and tear, wilful or accidental damage, misuse, neglect or any cause which is beyond the manufacturer's control.
5. The Warranty also does not cover modifications or repairs made to the product by unauthorised persons or the use of unauthorised parts, or any failure or malfunction due to incorrect installation and/or poor workmanship on the part of the installer, unless installed, serviced and maintained by Southern Care Systems Ltd or one of their appointed agents.
6. This Warranty does not affect your statutory consumer rights.

The standard 2 year Warranty is available for the following products, but with specific exclusions and conditions listed below:-

#### **Spectra Ceiling Track Hoists.**

Standard 2 year warranty excludes batteries.

**Servicing– LOLER requirements recommend that equipment to lift people shall be thoroughly examined by a competent person at 6-monthly intervals. European Standard BS EN10535 recommends hoists are serviced every 12 months, including a load test.**

**Within the terms of a standard 2 year warranty inspection and servicing is chargeable. Kindly ask your Spectra product supplier for details.**

#### **Spectra Turntable.**

Servicing and LOLER testing is included as part of a ceiling track hoist service agreement and as such follows the same requirements and recommendations.

#### **Spectra XY System.**

Servicing and LOLER testing is included as part of a ceiling track hoist service agreement and as such follows the same requirements and recommendations.



**Spectra Gantry.**

Gantry systems are usually supplied on a temporary term basis and as such will undergo checking and testing upon completion of contract or start of new contract (if this runs concurrently) or return to manufacturer or approved dealer.

In the event the gantry requirement has been extended, an appointment should be made for a service/LOLER test six monthly.

**Duty Holder**

(if not Southern Care Systems Ltd)

**Spectra Care Group**

Registered Address: Unit 1a Hightown Industrial Estate,  
Crow Arch Lane, Ringwood, Hampshire, BH24 1ND

**Southern Care Systems Ltd**

Unit 1a Hightown Industrial Estate,  
Crow Arch Lane, Ringwood, Hampshire, BH24 1ND  
Tel: 01425 471522. Fax: 01425 479130.